

Vision is
our mission®

Camera EMOS 180° Ethernet
Article no. 0186000

Camera EMOS 120° Ethernet
Article no. 0186010

Camera EMOS 90° Ethernet
Article no. 0186020

Camera EMOS 60° Ethernet
Article no. 0186030

Camera EMOS 30° Ethernet
Article no. 0186040

2019 • DS0961110 EN A 06



New Generation digital
High resolution camera;
using fast Ethernet video link

Product Data

Dimensions

Only by
Art. no. 0186000
this size is 24mm

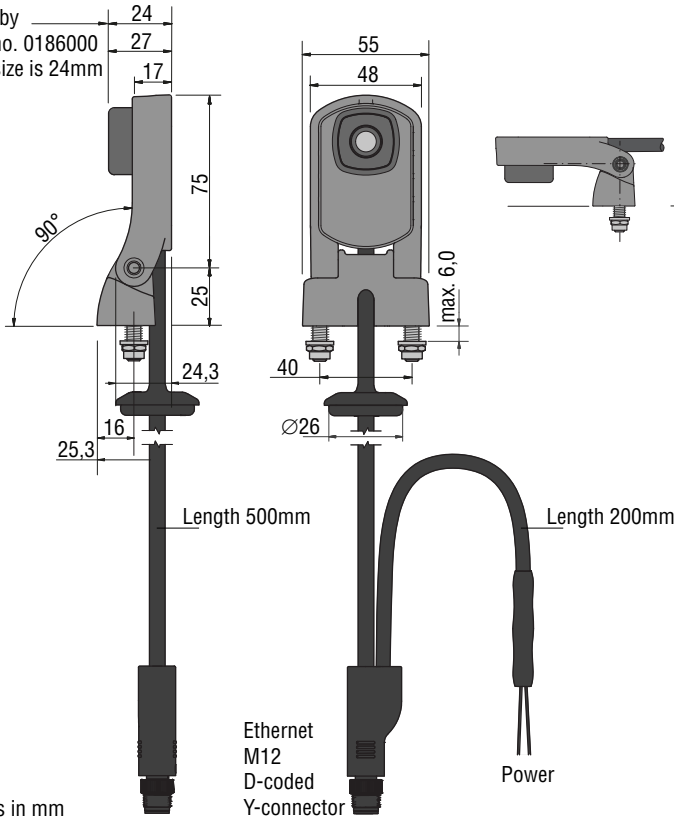

Mounting options

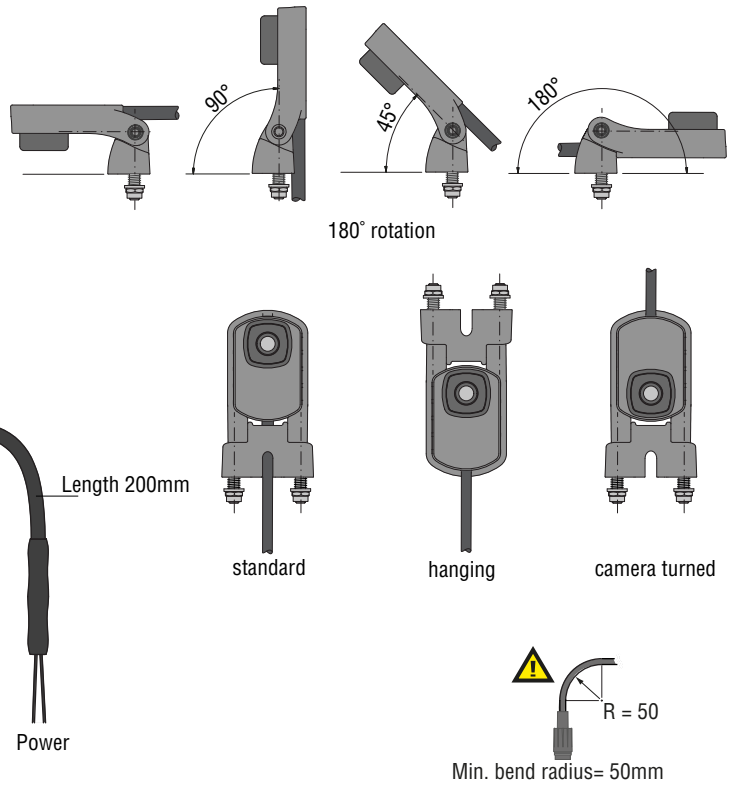

TECHNICAL DATA

Camera EMOS Ethernet

	Description				
Article number	0186000	0186010	0186020	0186030	0186040
Lens specified	180°	120°	90°	60°	30°
Horizontal lens angle	180°	120°	90°	60°	30°
Vertical lens angle	130°	91°	68°	45°	22°
Sensor element	High resolution 1/3" CMOS rolling shutter, 1280H x 960V.				
Video image	60fps at 720p SDR, 45fps at 960p SDR image processing and 56fps at 720p HDR, 43fps at 960p HDR image processing.				
Protocols	RTP (MJPEG RFC2435 and h.264 RFC6184) over UDP, ISO17215-2014, IEEE1722 (AVB), ARP.				
IP address	DHCPv4 or static IPv4 (IPv6 possible).				
Latency	<100ms depending on hardware processing platform (50ms demonstrated on Orlaco hardware).				
Light sensitivity	responsivity 5,5V/lux-sec, Low light feature (<0,1Lux).				
High dynamic range	>115dB.				
Compression	MJPEG, H.264 (High 10 intra profile encoding).				
Interface	100Mb/s (Fast Ethernet).				
Image processing	Color and gamma correction, 3D noise correction, edge enhancement, digital WDR, advanced contrast enhancement, auto white-balance, auto exposure control, mirroring, flipping, photometric and geometric lens distortion correction.				

Electrical

Power input	12/24V/DC. Below 7V: camera is non-functional. Above 33V the overvoltage protection is activated. This overvoltage-protection is deactivated below 30V. Powercircuit is protected up to 80V/DC. Outputs are Short Circuit Protected. In all these above mentioned values; a tolerance of +/-10% is applied.
Power consumption	<2W.
Transient protection	Camera may be powered directly from 12V or 24V battery without additional electrical protection since camera has an integrated circuit that protects the camera against over- and undervoltage, spikes, ripples and loaddumps (ISO-Pulses).
Connector/Cable	6 wire: 2x twisted pair for data and 2 wires for power supply. Connector 4-pin M12 d-coded for data and open wires for power supply. Length cables: see Dimensions, page 1.
Min. cable bend radius	50mm.

Mechanical

Housing	Anodised aluminium, black, UV resistant, light fastness >8, corrosion proof according IEC 60068-2-52 salt mist, cyclic.
Filling	Camera is potted with automotive potting resin
Ingress protection	IP67 according to IEC 60529; dust tight and protected against the effects of immersion in water up to 1m under water for 30 minutes. IP69k according to DIN 40050-9: camera can withstand a high pressure cleaning with water: 14-16L/min. 80°C and 100 bars flow.
Shock constancy	Shock and vibration resistant for usage on trucks, cranes, fork-lifts, maritime applications, machinery.
Camera bracket	Material: glass reinforced plastics, test: 50 Nm at -40°C to +85°C. Mounting hardware standard stainless steel.
Weight	0,24kg. including cable, bracket and mounting material. 0,30kg. in standard packing.
Truck use	Withstand all fluids and materials used in and around trucks like: ammonia solution 5%, ethanol 80-100%, isopropanol 5-10%, soapy water (min. 50% soap per volume), alkaline degreasing compounds(used in high pressure washing equipment).
Operating temperature	-40°C to +85°C.
Storage temperature	-40°C to +125°C.

Certification

Approvals	In compliance with all relevant EMC- and Automotive directives. This device complies with Part 15 of the FCC Rules. Operation is subject to the following conditions: (1) this device may not cause harmful interference, and (2) this device must accept any interference received, including interference that may cause undesired operation. Certificates available upon request. Compliant with RoHS and REACH.
------------------	------------------------------------------------------------------------------------------------------------------------------------------------------------------------------------------------------------------------------------------------------------------------------------------------------------------------------------------------------------------------------------------------------------------------

Features

This camera complies to	R10 ECE regulations. FCC regulations. EN 12895 (2000) Industrial trucks – Electromagnetic Compatibility. EN 13309 (2010) Construction machinery – E.C. of machines with internal power supply. EN ISO 14982 (2009) Agricultural and forestry machinery - Electromagnetic Compatibility. ISO 13766 (2006) Earth-moving machinery - Electromagnetic Compatibility.
--------------------------------	---------------------------------------------------------------------------------------------------------------------------------------------------------------------------------------------------------------------------------------------------------------------------------------------------------------------------------------------------------------------------------

All data subject to change without notice. All dimensions are for commercial purpose only.

The camera/display systems from Orlaco comply with the latest CE, ADR, EMC and mirror-directive regulations, where applicable.

All products are manufactured in accordance with the ISO 9001 quality management system, IATF 16949 quality automotive, ISO 14001 environmental management systems and all Ex products with the IECEx scheme and ATEX directives, where applicable.

