

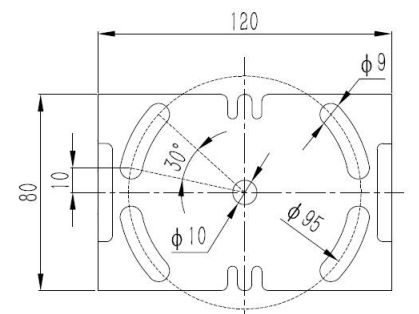

- IP 69K
- Anti-Shocks
- Anti-Vibration
- Low Latency
- Wide Angle

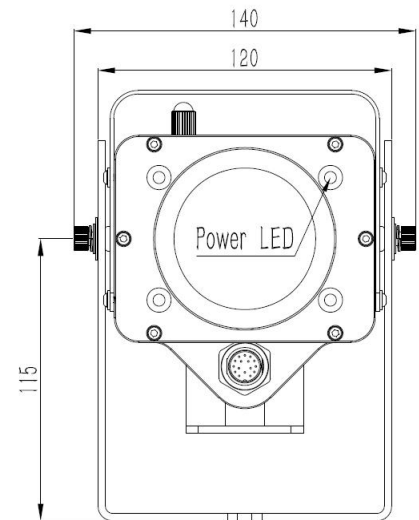
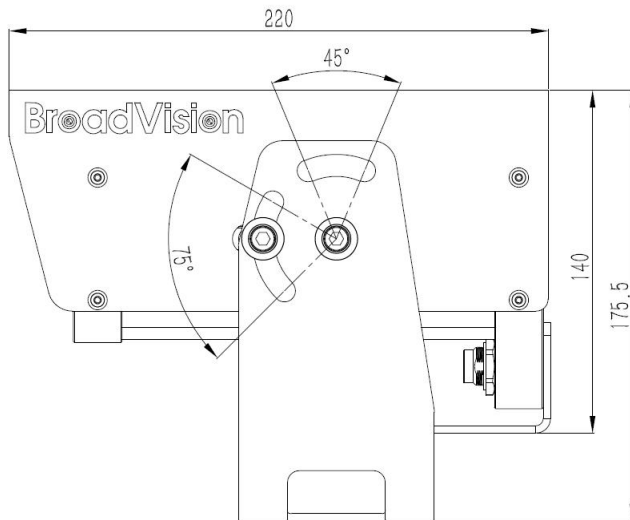

Unit: mm

Product Data

# TECHNICAL DATA

## Camera AFZ-HD-A(W)

### Camera

Sensor	1/2.8" Progressive Scan CMOS
Resolution	Max: 2560×1440 ( 60Hz, 30fps )
Focus	2.8mm to 12mm
Zoom	4X optical zoom
Aperture	F1.6 - F3.0
Angle of view	H: 96° to 29.39°, V: 16.63° ~51°
M.O.D	100mm to 1500mm
Min.illumination	ICR-Off: 0.001Lx; ICR-On: 0.0005Lx
Shutter speed	1/25 to 1/100000s
S/N ration	52dB
Standards	H.265, H.264
Latency	110ms ( 2560×1440, 30fps )
Zoom speed	≈2s
Start up time	<30s

### General

Protocols	TCP/IP, ICMP, HTTP, HTTPS, FTP, DHCP, DNS, RTP, RTSP, RTCP, NTP, SMTP, SNMP, IPv6 ONVIF(PROFILE S, PROFILE G), GB28181
Control	RS485, UART, I/O

### Electrical

Input Voltage	12~24V DC, 48V PoE
Power Rating	Heating off: 6W
Communication	100M Ethernet
Aviation Joint	M16 Screw-type Waterproof Connector
Cable	1.5m, Open wired, Customizable length
Safety measure	Lightning/Overvoltage/Reverse Protection

### Electrical Connections

1_Orange/White	Ethernet TX+	9_Yellow/White	RS 485A+
2_Orange	Ethernet TX-	10_Yellow	RS 485B-
3_Green/White	Ethernet RX+	11_Purple/White	COM 1
4_Green	Ethernet RX-	12_Purple	COM 2
5_Blue/White	NC.	13_NC.	/
6_Blue	NC.	14_NC.	/
7_Brown/White	NC.	15_Red	DC+ 12/24V
8_Brown	NC.	16_Black	DC-

### Mechanical

Structural	316L Stainless steel mounting parts & sun cover, anodized aluminium housing, CNC integrated molding
Anti-Corrosion	Salt mist, cyclic (IEC 60068-2-52)
IP Grade	IP68 ( IEC60529 ) dustproof & waterproof ( dip in water up to 3m for 60 minutes ) IP69K ( DIN 40050-9 ) suffer high pressure washing ( 14-16L/min, 80°C, 100 bar )
Inner Fill	Dry-nitrogen filled, 1.4 Bar overpressure
Anti-Shock	50G, 6ms, Half sine wave
Bracket	316L stainless steel, including bolts, nuts and washers. Suitable for mounting overhead and standing.
Working Temp.	-30°C to +60°C
Glass	Vacuum nano-coated glass, 5* stronger than ordinary glass. With Anti-fog coating AF coating & AR coating ( up to 95% VLT)
Weight	2.4kg

### Cable

Jacket	PUR, matte black
Outer diameter	8.6±0.2mm
Filler material	Cotton
Shield	Tin plated copper
Conductor	Oxygen-free copper wire
CO.resistance	35 Ohm/KM ( 20°C )
IN.resistance	0.15 MOhm/KM ( 20°C )
Voltage level	300V/500V
Rated Temp.	-40~90°C
Standards	DRGB/2016

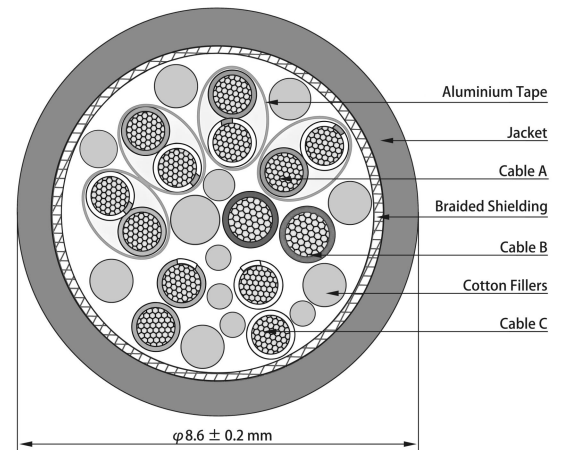

All data subject to change without notice. All dimensions are for commercial purpose only.  
The camera from BroadVision comply with the latest CE, FCC, EMC and mirror-directive regulations, where applicable.  
All products are manufactured in accordance with the ISO 9001 quality management system, ISO 14001 environmental management systems and ISO 45001 occupation health safety management system, where applicable.